

# LXC63X0 / LXC51X0

Generator controller user manual.

Ver1.2 Date: 2013/06/06



Without our company consent, no part of this manual can not be copied (including pictures and icons). The Company reserves the right to change the contents of this manual without notifying the user.

## Version history

Date	Ver	content
2010-10-20	1.0	Start publishing
2011-08-21	1.1	Increased DTU binding and remote monitoring function
2013-06-06	1.2	Increase the panel can set parameters of the items

## CONTENTS

1. Technical Parameter.....	3
2. Introduction.....	4
2.1. Main Features.....	4
2.2. Special industry application characteristics.....	4
3. Operate.....	6
3.1. Key Function.....	6
3.2. Automatic start/stop operation.....	6
3.2.1 Starting Sequence:.....	6
3.2.2 Stopping sequence:.....	7
3.3. Test Mode Start/Stop Operation.....	7
3.4. Manual Start/Stop Operation.....	7
3.5. Manual Stop.....	8
3.6. LXC6320/5120 Switch control procedures.....	8
3.6.1. Manual transfer procedures.....	8
3.6.2. Auto transfer procedures.....	8
3.7. LXC6310/5110 Switch control procedures.....	9
3.7.1. Manual transfer procedures.....	9
3.7.2. Auto control procedures.....	9
4. SMS remote control、 wireless remote control function description.....	9
4.1. BASED ON THE GPRS DTU REMOTE ONLINE MONITORING.....	11
4.2. DTU WITH THE BINDING OF THE CONTROLLER.....	12
4.3. MULTILEVEL PASSWORD MANAGEMENT.....	12
4.4. HISTORY QUERY.....	13
4.4.1 Event log.....	13
4.4.2 History alarm.....	14
5. Protection.....	15
5.1. Warnings.....	15
5.2. Shutdown Alarm.....	16
5.3. Trip Alarm.....	16
5.4. SMS alarm.....	17
6. WIRINGS CONNECTION.....	17
6.1. Description Of Terminal connection:.....	18
7. Parameter setting.....	19
7.1. Date and time setting:.....	19
7.2. Operating parameters:.....	19
7.3. Parameter setting, content and scope of list.....	20
7.4. Programmable output port can be defined content table 1-6.....	24
7.5. Programmable input port 1-6 definition content list.....	27
7.6. Custom Project Name List.....	28
7.7. Sensor selection list.....	29
7.8. Successful starting condition selection list.....	29
8. COMMISSIONING.....	30
9. Typical applications.....	31
10. Common Faults And Exclusion Method.....	35
11. Product Packaging.....	35

# 1. Technical Parameter

Project	Pontent
Operating Voltage	DC8.0V to DC35.0V, Continuous Power Supply.
Power Consumption	< 3W ( standby:≤ 2W )
Alternator Input Range 3 -Phase 4-Wire 3 -Phase 3-Wire Single-phase 2-wire 2 -Phase 3-Wire:	20V AC - 360 V AC (ph-N) 30V AC - 600 V AC (ph-ph) 20V AC - 360 V AC (ph-N) 20V AC - 360 V AC (ph-N)
Alternator Frequency	50/60Hz
Speed sensor voltage VPP	1.0 to 70V(Peak to peak )
Speed sensor Frequency	30-10000Hz
Start Relay Output	16Amp Controller Power Voltage Output
Fuel Relay Output	16Amp Controller Power Voltage Output
Programmable Relay Output 1	16Amp Controller Power Voltage Output
Programmable Relay Output 2	16Amp Controller Power Voltage Output
Programmable Relay Output3	16Amp Controller Power Voltage Output
Programmable Relay Output4	16Amp 250VAC voltage free output
Close Generator Relay Output 5	16Amp 250VAC voltage free output
Close Mains Relay Output 6	16Amp 250VAC voltage free output
Case Dimension	240mm x 172mm x 57mm
Panel cutout	214mm x 160mm
C.T. Secondary	5A Rated
Working Conditions	Temperature: ( -25 ~ 70 )°C and humidity: ( 20 ~ 90 ) %
Storage Condition	Temperature:(-40 ~ + 70)°C
Protection Level	IP55: when waterproof rubber seal installed between controller and panel fascia. IP42: when waterproof rubber seal is not installed between the controller and panel fascia.
Insulating Intensity	Object: input/output/power Quote standard: IEC688-1992 Test way: AC1.5kV/1min leakage current: 3mA
Weight	0.90kg

## 2. Introduction

LXC6310/LXC6320/LXC5110/LXC5120 series controllers real-time systems using 32-bit microprocessor control technology to achieve 16 kinds of precise parameters of measurement, 32 kinds of input, 35 kinds of warning protection, 85 kinds of output, and the parameters almost can be adjusted by keypad. It can show engine and generator parameters on LCD graphics display. It has rapidly applied to many areas, such as: small power plants, biogas power generation, oil and power, field engineering, factory, fire pumps, mobile base stations and many other fields. For gasoline, diesel, natural gas, biogas and other power equipment, many well-known company inland and abroad has been widely supporting applications.

### 2.1. Main Features

- ❖ With ARM-based 32-bit MCU, highly integrated hardware, new reliability level;
- ❖ 132x64 LCD with backlight, multilingual interface (including English, Chinese or other languages), 98% of the parameters can be set on the controller to facilitate the commissioning test machine;
- ❖ Start control and protection functions, automatic Start & Stop gen-set, ATS(Auto Transfer Switch) control with perfect fault indication and protection function;
- ❖ All parameters can be using a PC via USB, RS232, RS485 interface adjust, and memory in the internal FLASH memory in the system when power is not lost;
- ❖ RS485 communication port enabling remote control, remote measuring, remote communication via ModBus protocol;(RS485 is optional);
- ❖ Equipped with SMS (Short Message Service) function. When gen-set is alarming, controller can send short messages via SMS automatic to max.5 telephone numbers. User can control or check gen-set by sending Short Message. Equipped with advanced networking capabilities, via GPRS mobile network and Internet connectivity, in any place where the network can be remotely monitor(GPRS module to be installed: LXI680);
- ❖ Variety of starting conditions for success (speed sensor, oil pressure, generator frequency, charging alternator) to choose from, suitable for all occasions applications;
- ❖ Fault history with 200, and can record the fault instant oil pressure, water temperature, voltage, current and other important parameters;
- ❖ Equipped with real-time clock, scheduled start & stop generator (can be set as start gen-set once a day/week/month with load or not), reach automatic maintenance;
- ❖ All output ports are relay-out;
- ❖ Five fixed analog sensors (two temperature, two oil pressure, level), two programmable analog sensor can be set to the temperature or pressure or level sensor. A variety of temperature, oil pressure, level sensor curve can be used directly and customize sensor curve;
- ❖ Widely power supply range DC(8~35)V, suitable to different starting battery voltage environment.

### 2.2. Special industry application characteristics

- ❖ Leasing industry applications: management provides the perfect solution: leased out via PC remote management of the unit, you can monitor all operating parameters (oil pressure, water temperature, voltage, current, power, etc.), you can always change the configuration to protect the unit is not proper application, can record 200 detailed fault information, including: time to failure, because, when the voltage, current, power, oil pressure, water temperature and other key parameters, and ready to upload to the monitoring machine. Another multi-level password management options to facilitate the lease management;
- ❖ Fire pump industry applications: Close electrical parameter measurement function, use powerful programmable input and output ports and internal programmable logic to achieve automated pump control system. Instead of the conventional engine controller PLC + simple manner, making the system more stable and reliable;
- ❖ Air compressor industry applications: Close voltage measurements protection, according to the need to configure programmable analog input, overload protection, with programmable digital inputs, complete startup control, temperature and pressure control, protection parameter settings.

❖ **Fully functional, and can detect almost all the generating units of electrical parameters and non-electrical parameters**

**Mains**

Line voltage      Uab, Ubc, Uca  
Phase voltage    Ua, Ub, Uc  
Frequency        Hz

**Gens**

Line voltage      Uab, Ubc, Uca  
Phase voltage    Ua, Ub, Uc  
Frequency        Hz  
Load current     IA, IB, IC  
Each phase and total active power      kW  
Each phase and total reactive power    kVar  
Each phase and total apparent power    kVA  
Each phase and average power factor    PF  
Accumulate total gens power      kWh, kVarh, kVAh

**Sensor**

Temperature WT    °C/ °F Choose to display  
Oil pressure       OP kPa/Psi/Bar Choose to display  
Fuel level (FL)    %(unit)  
Speed (SPD)      RPM(unit)  
Voltage of Battery (VB)      V (unit)  
Voltage of Charger (VD)      V (unit)  
Hour count (HC) can accumulate Max. 65535 hours.  
Start times can accumulate Max. 65535 times

**Mains and generator abnormal conditions:**







Voltage is too high  
Voltage is too low  
Frequency is too high  
Frequency is too low  
Phase loss  
Loss of power

**The fault display and protection function project:**

High water temperature warn  
High water temperature shutdown alarm  
Low oil pressure warning  
Over speed shutdown alarm  
Box high temperature warn  
Low fuel level warn  
Battery voltage is too high warn  
Battery voltage is too low warn  
Load over current shutdown alarm  
Failed to stop alarm  
Emergency stop alarm  
Oil pressure sensor open circuit shutdown alarm

## 3. Operate

### 3.1. Key Function

	Stop/ Reset key	This button places the module into its Stop/reset mode. When engine is running, pressing this key will stop the engine. When a shutdown alarm occur, pressing this key will reset alarm.
	Start key	In manual or manual test mode, pressing this key will start engine.
	Manual mode key/ Config “-” key	Pressing this key will set the module into manual mode. In setting parameter status, pressing this key will decrease setting value.
	Manual test mode/ Config “+”key	Pressing this key will set the module into manual test mode. In setting parameter status, pressing this key will increase setting value.
	Auto key / Config “enter” key	Pressing this key will set the module into automatic mode. In setting parameter status, pressing this key will shift cursor or confirm setting value.
	View history record key	Press this button to display abnormal shutdown generator set records, press the key again to exit.
	Scroll key	In the parameter display and record query screen, press this key to make a scroll operation.

### 3.2. Automatic start/stop operation

Press , its indicator lights, and controller enters Auto mode.

#### 3.2.1 Starting Sequence:





1. LXC6320/5120:When Mains is abnormal (over and under voltage, over and under frequency, loss of phase, phase sequence wrong), it enters into mains "abnormal delay" and LCD display count down time. When mains abnormal delay is over, it enter into "start delay".
2. LXC6310/5110:Generator enters into "start delay" as soon as "Remote Start on Load" is active.
3. Start Delay timer is shown on Status page of LCD.
4. When start delay is over, preheat relay outputs (if this be configured), "preheat start delay XX s" is shown in LCD.
5. When preheat delay is over, fuel relay outputs 1s and then start relay output; if engine crank fails during "cranking time", the fuel relay and start relay deactivated and enter into "crank rest time" to wait for next crank.
6. If generator crank fails within setting times, controller will send "Fail to start" and the warning will be shown on LCD at the same time.
7. In case of successful crank attempt, "safety on timer" starts. During this period, low oil pressure, high water temperature, under speed, charge failure alarms are disabled. As soon as this delay is over, "start idle delay" is initiated (if configured).
8. During "start idle delay", under speed, under frequency, under voltage alarms are inhibited. When this delay is over, "warming up delay" starts (if configured).

9. When "warming up delay" is over, if generator state is normal, its indicator will be illuminated. If voltage and frequency has reached on-load requirements, the closing relay will be energised, generator will accept load, generator power indicator will turn on, and generator will enter Normal Running state; if voltage and frequency are abnormal, the controller will initiate alarm (alarm type will be displayed on LCD alarm page).



### 3.2.2 Stopping sequence:

- 1.LXC6320/5120: When mains return normal during gen-set running, enters into "mains voltage Normal delay". When mains normal delay are over, enter into "stop delay".
- 2.LXC6310/5110:Generator enters into "stop delay" as soon as "Remote Start on Load" is inactive.
3. When stop delay is over, close generator relay is un-energized; generator enters into "cooling time delay". After "transfer rest time", close mains relay is energized. Generator indicator extinguish while mains indicator lights.
4. Idle relay is energized as soon as entering "stop idle delay".
5. If enter "ETS hold delay", ETS relay is energized. Fuel relay is deactivated and decides whether generator is stopped or not automatically.
6. Then enter gen-set "Fail to stop timer", auto decides whether generator is stopped or not.
- 7.When the generator stopped, enter the standby generator; If the generator does not stop the controller alarm (LCD Screen Display Shutdown failure warning).

### 3.3. Test Mode Start/Stop Operation

1.LXC63X0/51X0: Press , controller enters into Manual starts mode and its indicator lights. Press  then controller enters into "Manual Test Mode" and its indicator lights. In the both mode, press  to start generator, can automatically detect crank disconnected, and generator accelerates to high-speed running. With high temperature, low oil pressure and abnormal voltage during generator running, controller can protect genset to stop quickly (please refer to No.4~9 of Auto start operation for detail procedures). In "Manual Test Mode ", generator runs well, whether mains normal or not, loading switch must be transferred to generator side. Manual startup and shutdown operation. In "manual mode ", the procedures of ATS please refer to ATS procedure of generator in this manual.

### 3.4. Manual Start/Stop Operation

LXC63X0/51X0: Press , controller enters into Manual starts mode and its indicator lights. Then press  to start generator, can automatically detect crank disconnected, and generator accelerates to high-speed running. With high temperature, low oil pressure and abnormal voltage during generator running, controller can protect genset to stop quickly (please refer to No.4~9 of Auto start operation for detail procedures). After generator runs well, if remote start signal is active, controller will send closing gens signal; if the remote signal is inactive, controller won't send closing signal.

### 3.5. Manual Stop

Press  can stop the running generator (please refer to No. 3 ~ 7 of Auto stop operation for detail procedures).

Start / stop timing diagram :

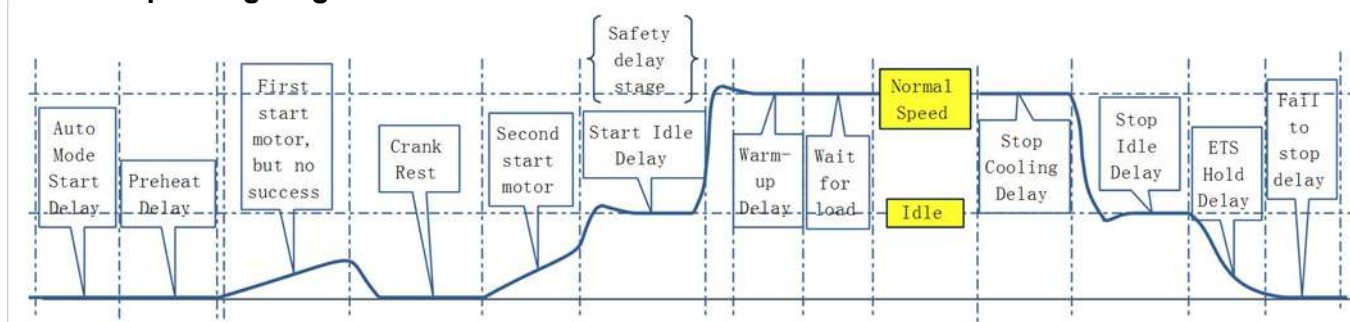

### 3.6. LXC6320/5120 Switch control procedures

#### 3.6.1. Manual transfer procedures

When controller is in Manual mode, the switch control procedures will start through manual transfer. Users can control the loading transfer of ATS via pressing button to switch on or off. But according to the ATS switch configuration is different, the specific process have some distinction.

❖ If "Open breaker detect" is "SELECT Disable"

After the press power close break-brake key, according to the current load case in 2 processes:

- 1: generator is opened when the generator is load; If the load is closed, the generator is open;
- 2: Mains is opened when the mains is load; When the end of the sub-gate delay generator closing; Press mains close or open key, if mains have taken load, will output unload open; If the load is opened, the mains close; If the generator is load, the generator to open, when the end of the open delay, then mains to close.

❖ If "Open breaker detect" is "SELECT Enable" and "Closing auxiliary input"

Principles as above, but in every time after closing and break-brake auxiliary input switching state through testing to determine. If not normal will be closing or opening failure warnings. **Note: This warning can be resolved by the alarm mute.**

#### 3.6.2. Auto transfer procedures

When controller is in Manual Test, Auto or Stop mode, switch control procedures will start through automatic transfer.

If "Open breaker detect" is "SELECT Disable" and "Closing auxiliary input"

- 1: When transferring load from mains to generator, controller begins detecting "fail to transfer", then the open delay and transfer rest delay will begin. When detecting time out, if switch open failed, the generator will not switch on, otherwise, generator switch on. Detecting transfer failure while gens switch on. When detecting time up, if switch on fail, it is need to wait for generator to switch on. If transfer failed and warning "SELECT Enable", there is alarming signal whatever switch on or off failure. **Note: This warning can be resolved by the alarm mute.**
- 2: Gens to a the mains load, the same principle.

If "Open breaker detect" is "SELECT Disable"

- 1: Mains load is transferred into generator load, after the delay of switch off and transfer interval, generator



switch on. Detecting transfer fail while generator switch on. After detecting time up, if switch on fail, then wait for generator switch on. If transfer fail and warning "SEL Enable", there is alarming signal.

2: Gens to a the mains load, the same principle.

#### **If input port not configured as Close Mains Auxiliary**

Mains load be transferred into gens load, after switch off and transfer interval delay, gens switch on.



**NOTE:** When using ATS of no interposition, switch off detecting is "SELECT Disable"; When using ATS of having interposition, switch off "SELECT Disable" or "SELECT Enable" both are OK. If choose "SELECT Enable", switch off output should be configured.

## **3.7. LXC6310/5110 Switch control procedures**

### **3.7.1. Manual transfer procedures**

When controller is in Manual mode, manual transfer will be executive. Users can control switch on or off by pressing key. Press generator switch on or off key, if generator have taken load, will output unload signal; if taken no load, generator will output load signal.

### **3.7.2. Auto control procedures**

When controller is in manual test, auto or stop mode, switch control procedures will start auto transfer.

#### **❖ If input port is configured as Close Mains Auxiliary**

##### **1: If "Open breaker detect" is "SELECT Disable"**

Gens load is transferred into generator un-load, after the delay of switch off, detecting transfer failure while switch off output. When detecting time up, if switch off failed, to wait for switch off. Otherwise, switch off is completed. Gens unload is transferred into gens load, after the delay of switch on, detecting transfer failure while switch on outputting. When detecting time up, if switch on failed, to wait for switch on. Otherwise, switch on is completed. If transfer failed and warning "SEL Enable", there is alarming signal whatever switch on or off failure.

##### **2: If "Open breaker detect" is "SELECT Enable"**

Gens load is transferred into gens unload, after the delay of switch off, switch off is completed. Gens unload is transferred into gens load, after the delay of switch on, detecting transfer failure while switch on outputting. When detecting time up, if switch on failed, to wait for switch on. Otherwise, switch on is completed. If transfer failure warning is "SEL Enable", there is warning signal that "switch on fail".

#### **❖ If input port is not configured as Close Mains Auxiliary**

Gens un-load is transferred into gens load, gens switch on and output.  
Gens load is transferred into gens un-load, gens switch off and output.

## **4. SMS remote control, wireless remote control function description**

SMS code is described as follows



**Note:** If the operation of the controller, the controller internally set to fly letter phone number can not start with a "+86";



**Note:** Write text messages are not case sensitive, but must be written in strict accordance with the instructions in the format, the spaces between all the words are a bit of spaces, all commands have to wait until the return code indicates that the operation is valid only.

NO.	SMS Command	SMS return information	Description
1	SMS GENSET	GENSET ALARM	When genset is stopping to alarm
		SYSTEM IN STOP MODE GENSET AT REST	At rest status in stop mode
		SYSTEM IN MANUAL MODE GENSET AT REST	At rest status in manual mode
		SYSTEM IN TEST MODE GENSET AT REST	At rest status in test mode
		SYSTEM IN AUTO MODE GENSET AT REST	At rest status in auto mode
		SYSTEM IN STOP MODE GENSET IS RUNNING	Running status in stop mode
		SYSTEM IN MANUAL MODE GENSET IS RUNNING	Running status in manual mode
		SYSTEM IN TEST MODE GENSET IS RUNNING	Running status in test mode
		SYSTEM IN AUTO MODE GENSET AT RUNNING	Running status in auto mode
		2	SMS START
GENSET IS RUNNING	The generator is running		
SMS START INHIBIT	SMS start prohibited		
STOP MODE NOT START	Cannot start in stop mode		
SMS START OK	Start in manual or auto mode		
AUTO MODE START OK	In automatic mode start		
3	SMS STOP IN AUTO MODE	AUTO MODE STOP OK	In automatic mode stop
4	SMS STOP MODE	SMS STOP OK	Set as stop mode
5	SMS MANUAL MODE	SMS MANUAL MODE OK	Set as manual mode
6	SMS TEST MODE	SMS TEST MODE OK	Set as trial test mode
7	SMS AUTO MODE	SMS AUTO MODE OK	Set as auto mode
8	SMS INHIBIT START	INHIBIT START OK	Set as start inhibit
9	SMS PERMIT START	PERMIT START OK	Set as start permit
10	SMS DETAIL	Users check setting (As shown below)	Users can query through a text message multiple generators

## LXI680 connection diagram

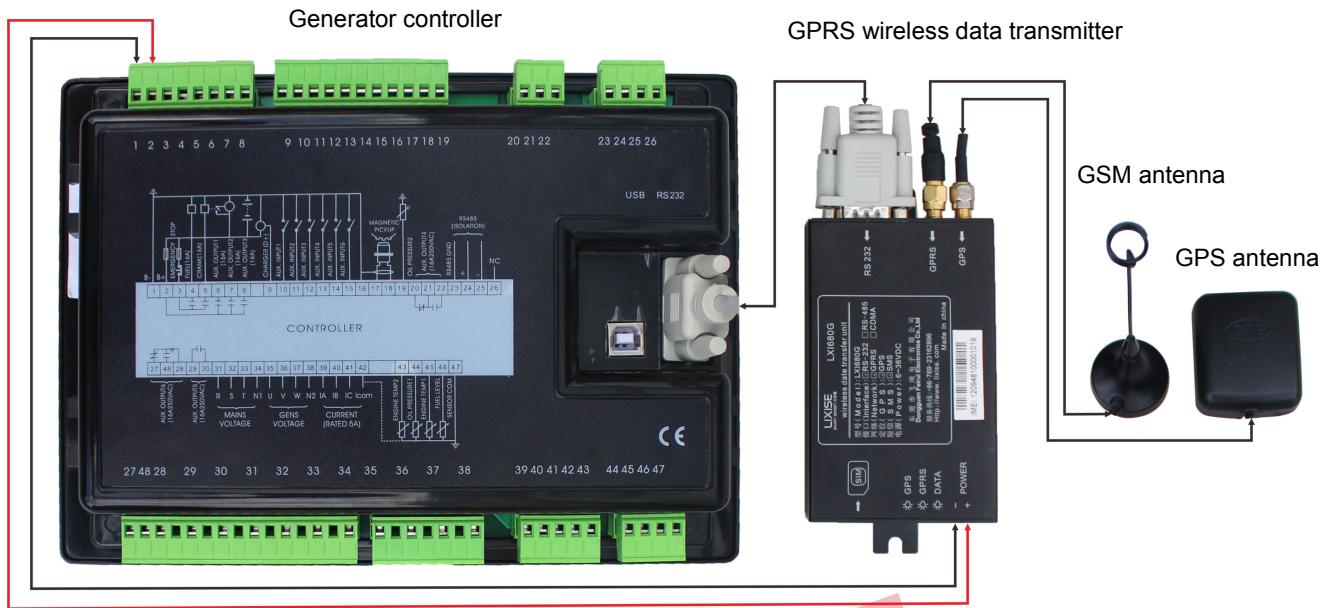

### 4.1. BASED ON THE GPRS DTU REMOTE ONLINE MONITORING

The program based on LXI680G provide wireless data transmission network, remote control operation of the generator on the Internet; and through the increase in the generator controller LXI680G Room communication protocol, so that the controller can the use of LXI680G SMS via SMS to control the generator run and generators receive alarm SMS.

Remark: LXI680G is Dongguan Feirui Electronics Co.,Ltd designed tailor-made for the generator controller wireless data transmission module, in particular to optimize the data exchange between the controller and the DTU, truly a fast and reliable data transmission.

Brief introduction: LXI680G is an industrial GPRS DTU with GPS global satellite positioning products. The product is integrated within the high-performance, low-power industrial-grade GPS module and GPRS module, GPS global positioning technology and GPRS wireless communication technology the perfect combination of a product.

LXI680G platform based on ARM and embedded operating system, built-in industrial-grade module, it can be used in harsh environments, working temperature range can be up to  $-40^{\circ}\text{C} \sim +85^{\circ}\text{C}$ . LXI680G provide standard RS232 serial interface, can be quickly and PLC, industrial control, instruments, meters, RTU equipment is linked together, through the GPRS network will be linked to LXI680G equipment data transmission to a host on the Internet, realize the data remote transparent transmission, at the same time to the front-end equipment of GPS location information reported to host, realize positioning of the equipment.

LXI680G with positioning, wireless data communications and data processing capabilities in a compact, rugged, reliable, easy to install, can be widely used in construction, transportation and other industries. Particularly suitable for tower crane monitoring, heavy machinery management, but also can be used in the field of taxi operations management, transport vehicles, special vehicles, vehicle rental management and leasing.

### LXC63X0/LXC51X0 Generator remote monitoring program

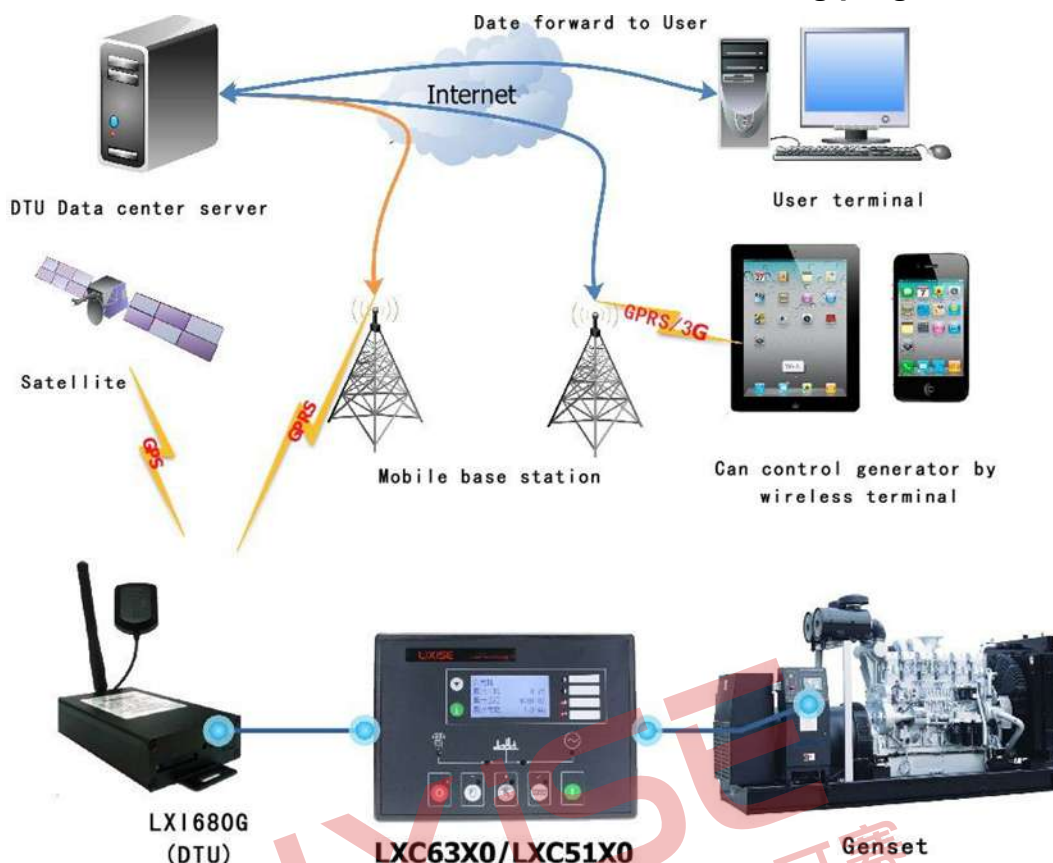

## 4.2. DTU WITH THE BINDING OF THE CONTROLLER

Controller and LXI680G after binding, it is only through the password to unbundling, if forced the controller and the DTU apart, the controller will record the alarm and displayed on the LCD panel and the warning information, or refuse the next start generator (the user can set up the binding deal after failure), this feature is especially suitable for generator leasing industry.

## 4.3. MULTILEVEL PASSWORD MANAGEMENT

Users need to configure the parameters, through different permissions password input, the parameters of the controller will present different configuration interface.

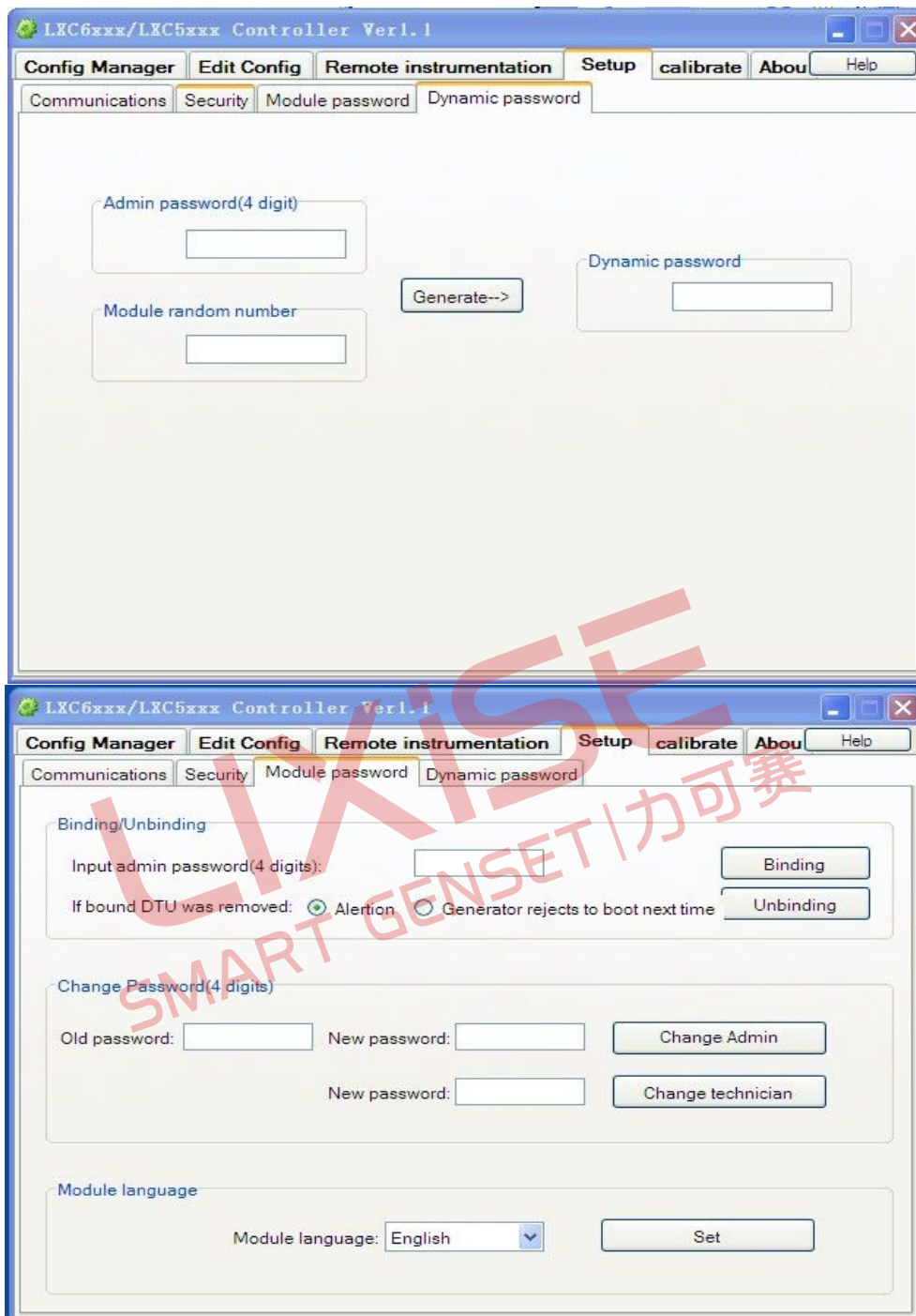

No	Password type	Extend of competence	Password modification	Unbound	Parameter configuration	Password Managers	Deadline
1	manager	All change permissions (dynamic password based on the password and the application code for calculating income)				Leasing companies	Long time
2	technician	Only have the parameter configure permissions (not can unbound)				Leasing Companies、Client	Long time
3	Dynamic password	Disposable (only has a one-time password parameter configure permissions, and unbound) can't change password				Dynamic calculations (Dynamic code provided by the customer)	Certain time effectively

### Password generation and change the interface



## 4.4. HISTORY QUERY

### 4.4.1 Event log

In the control panel, press  keys to view controller before abnormal shutdown record, including the time of the outage warning content display and the state, press  keys can search record back. Return

according to state controller real-time show press  key again. LXC63X0/LXC51X0 controller can record 99 abnormal downtime record recently.

### 4.4.2 History alarm

Controller will record the momentary generator all monitoring parameters. Users can remote access, easy to cause analysis, due to a single record data is more, the record can only be through monitoring software review, monitoring software can be through the DTU wireless remote read data.

**Record reading window**

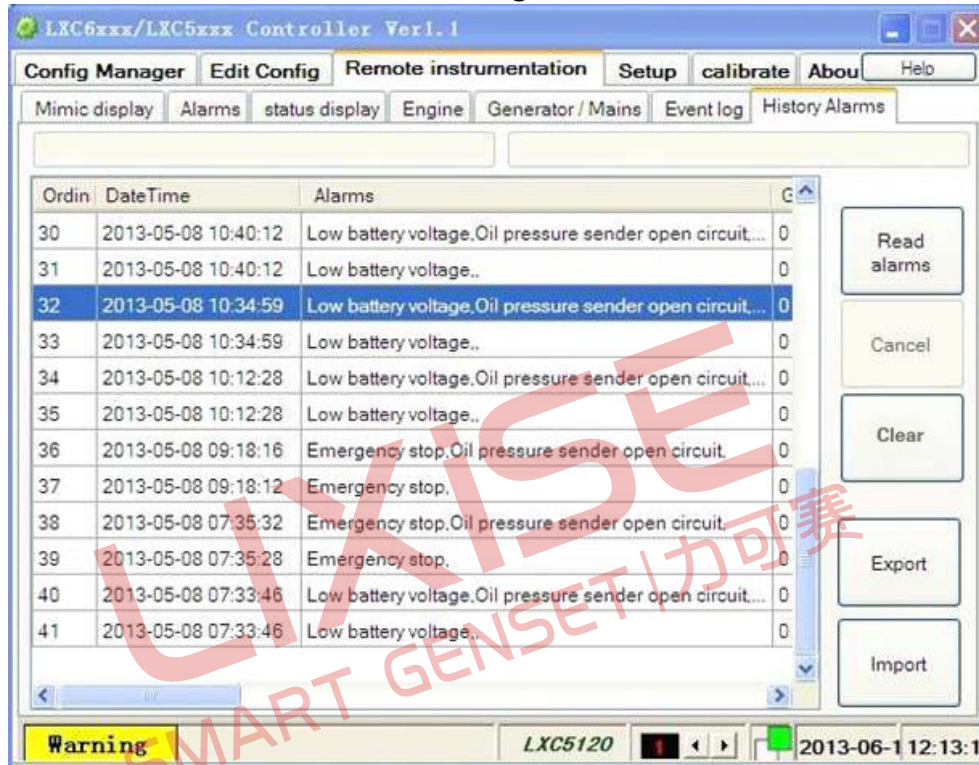

**Recorded data display window**



## 5. Protection

### 5.1. Warnings

When the controller detects warning signal, controller only warning does not stop, and the LCD display a warning alarm type.

The following table warning volume controller:

No	Warning type	Description
1	High Temp. Warn	When controller detects the temperature is higher than the set value, it will send a warn alarm signal and it will be displayed in LCD.
2	Low oil pressure warn	When controller detects the oil pressure is lower than the set value, it will send a warn alarm signal and it will be displayed in LCD.
3	Over Speed Warn	When controller detects the speed is higher than the set value, it will send a warn alarm signal and it will be displayed in LCD.
4	Under Speed Warn	When controller detects the speed is lower than the set value, it will send a warn alarm signal and it will be displayed in LCD.
5	Loss of Speed Signal Warn	When controller detects the speed is 0 and the action select "Warn", it will send a warn alarm signal and it will be displayed in LCD.
6	Over Frequency Warn	When controller detects the frequency is higher than the set value, it will send a warn alarm signal and it will be displayed in LCD.
7	Under Frequency Warn	When controller detects the frequency is lower than the set value, it will send a warn alarm signal and it will be displayed in LCD.
8	Over Voltage Warn	When controller detects the voltage is higher than the set value, it will send a warn alarm signal and it will be displayed in LCD.
9	Under Voltage Warn	When controller detects the voltage is lower than the set value, it will send a warn alarm signal and it will be displayed in LCD.
10	Over Current Warn	When controller detects the current is higher than the set value, it will send a warn alarm signal and it will be displayed in LCD.
11	Fail to Stop	When generator cannot stop after the "stop delay"/"ETS delay", controller will send warning alarm signal and it will be displayed in LCD.
12	Low Level Warn	When controller detects the oil level is lower than the set value, it will send a warn alarm signal and it will be displayed in LCD.
13	Charge Alt Fail	When controller detects the charger voltage is lower than the set value, it will send a warn alarm signal and it will be displayed in LCD.
14	Battery Under Voltage	When controller detects the battery voltage is lower than the set value, it will send a warn alarm signal and it will be displayed in LCD.
15	Battery Over Voltage	When controller detects the battery voltage is higher than the set value, it will send a warn alarm signal and it will be displayed in LCD.
16	Auxiliary input port 1-6 warning	When digit input port 1-6 is set as warning and active, controller sends corresponding warning signal.
17	DTU bind failed	When setting the DTU and the controller binding, if the DTU is artificially removed and disconnected from the controller, the controller will issue an alarm, the alarm operation is performed after the user can set.
18	Load conversion failed	Controller performs load switch, switch failure alarm is detected the alarm.

**Note: the auxiliary input port warning types, must be user configuration, to be effective.**

## 5.2. Shutdown Alarm

When controller detects shutdown alarm, it will send signal to stop the generator to load out, and the display alarm type.

Shutdown alarms as following:

No	Warning types	Description
1	Emergency Stop	When controller detects emergency stop signal, it will send a stop alarm signal and it will be displayed in LCD.
2	High Temperature	When controller detected the temperature of water/cylinder is higher than preset, it will send a stop alarm signal and it will be displayed in LCD.
3	Low Oil Pressure	When controller detected oil pressure is lower than the preset, it will send a stop alarm signal and it will be displayed in LCD.
4	Over Speed	When controller detected genset speed is over the preset, it will send a stop alarm signal and it will be displayed in LCD.
5	Under Speed	When controller detected genset speed is under the preset, it will send a stop alarm signal and it will be displayed in LCD.
6	Loss Of Speed Signal	When controller detected genset speed is 0 ,it will send a stop alarm signal and it will be displayed in LCD.
7	Over Frequency	When controller detected genset frequency is over the preset, it will send a stop alarm signal and it will be displayed in LCD.
8	Under Frequency	When controller detected genset frequency is under the preset, it will send a stop alarm signal and it will be displayed in LCD.
9	Over Voltage	When controller detected genset voltage is over the preset, it will send a stop alarm signal and it will be displayed in LCD.
10	Under Voltage	When controller detected genset voltage is under the preset, it will send a stop alarm signal and it will be displayed in LCD.
11	Over Current	When controller detected genset current is over the preset and delay is not 0, it will send a stop alarm signal and it will be displayed in LCD.
12	Fail To Start	During the start attempt times, if genset start failed, it will send a stop alarm signal and it will be displayed in LCD.
13	Oil Pressure Sensor Open	When oil pressure sensor opens circuit and the input is active, controller will send a stop alarm signal and it will be displayed in LCD.
14	Input Port 1-6	When controller detected the input port 1-6 external warning is active, controller will send shutdown alarm signal and it will be displayed in LCD.
15	D+ Open shutdown	Generator starting on the D+ connected to detect if an alarm when open.

**Note: the input port shutdown alarm types, must be user configuration, to be effective.**

## 5.3. Trip Alarm

When controller detects shutdown alarm signal, it will shutdown generator quickly and stop after high speed cooling.

Trips shutdown alarm as following:

No	Warning type	Detection range	Description
1	Over Current	Remain valid	When controller detects the value is higher than the set value, and the action select "trip and shutdown", it will send a trip alarm signal and it will be displayed in LCD.
2	Input port 1-6	The user setting range	When digital input port 1-6 is set as "trip and shutdown", and the action is active, it will send a trip alarm signal and it will be displayed in LCD.

**Note: the input port trip alarm types, must be user configuration, to be effective.**



## 5.4. SMS alarm

These items are sent via SMS to the user to set the GSM mobile communication terminal.

No.	Condition
1	Emergency stop
2	High temperature 1 shutdown
3	Low oil pressure 1 shutdown
4	Over speed shutdown
5	Under speed shutdown
6	Speed signal loss shutdown
7	Over frequency shutdown
8	Under frequency shutdown
9	Over voltage shutdown
10	Under voltage shutdown
11	Over current shutdown
12	Starting failure shutdown
13	Oil pressure sensor open shutdown
14	Input 1 shutdown
15	Input 2 shutdown

No.	Condition
16	Input 3 shutdown
17	Input 4 shutdown
18	Input 5 shutdown
19	Input 6 shutdown
20	D+ Open shutdown
21	Over current trip alarm
22	Input port 1 trip alarm
23	Input port 2 trip alarm
24	Input port 3 trip alarm
25	input port 4 trip alarm
26	input port 5 trip alarm
27	input port 6 trip alarm
28	High temperature 2 shutdown
29	Low oil pressure 2 shutdown

## 6. WIRINGS CONNECTION

LXC63X0/LXC51X0 controller's rear as following:

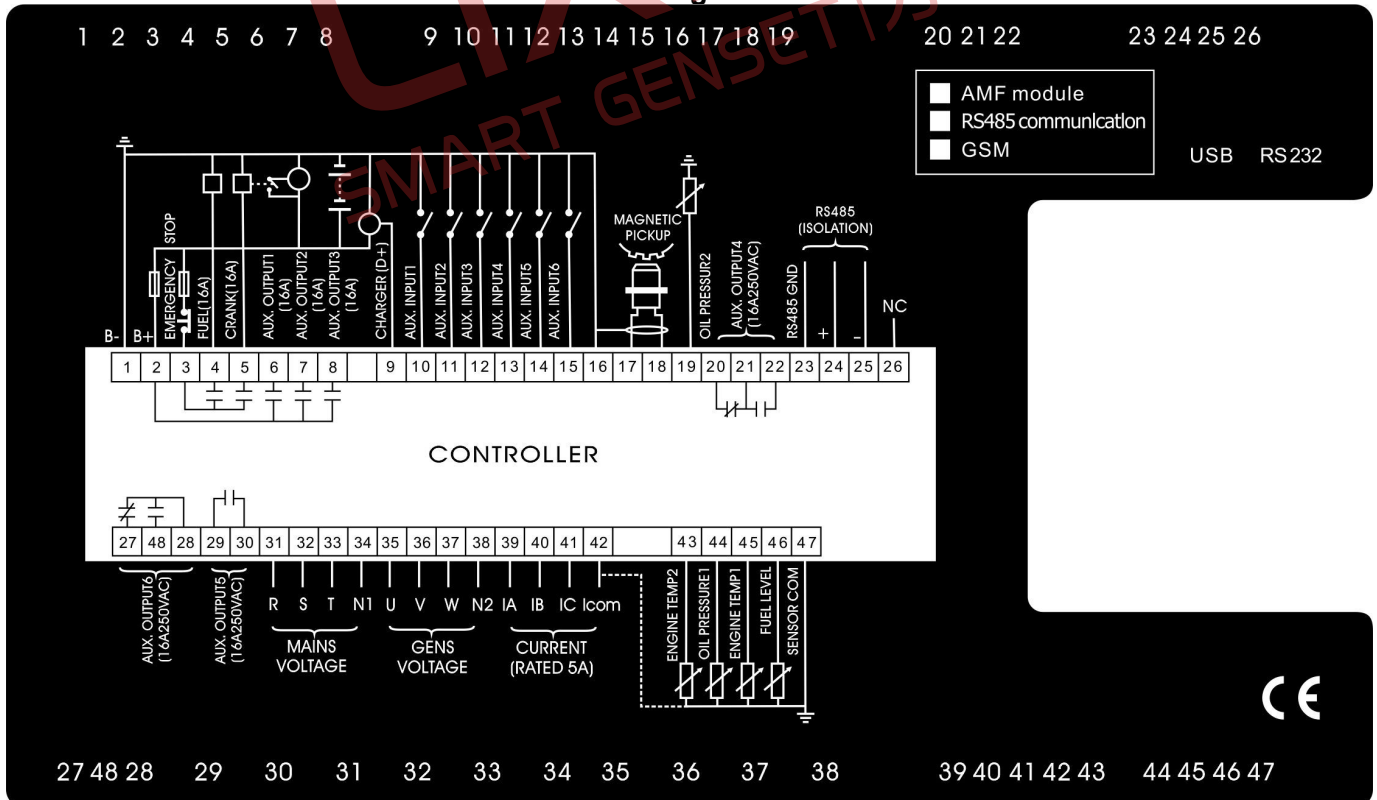



## 6.1. Description Of Terminal connection:

No	Function	Wire diameter	Description
1	DC input B-	2.5mm	DC negative input , connect to negative of starter battery.
2	DC input B+	2.5mm	DC positive input,connect to positive of starter battery.(20A fuse recommended).
3	Emergency stop	2.5mm	Plant Supply B+. Also supplies fuel & start outputs.(Recommended maximum 30A fuse).
4	Fuel relay output	2.5mm	B+ is supplied by 3 points, rated 16A.
5	Start relay output	2.5mm	
6-8	Aux. Output relay1-3	2.5mm	B+ output, rated 7A.
9	Charge failure input / excitation	1.0mm	Charging D+ input, do not connect to ground.
10-15	Aux. Output1-6	1.0mm	Switch to B-.
16	Magnetic Pickup	1.0mm	Common ground, which can be accessed chassis or starter battery negative.
17	Magnetic Pickup +	1.0mm	Connect to Magnetic Pickup device.
18	Magnetic Pickup -		
19	Oil Pressure2 Input	1.0mm	Connect to Oil pressure 2 sender.
20-22	Auxiliary Output relay 4	2.5mm	Free voltage contacts. 16 Amp rated.
23	NC		
24	RS485 The public	0.5mm	Isolated.
25	RS485+	0.5mm	
26	RS485-	0.5mm	
27-28 48	Auxiliary Output relay 6 (close mains output)	2.5mm	Free voltage contacts, N/C, 16 Amp rated.
29-30 54	Auxiliary Output relay 6 (close generator output)	2.5mm	Free voltage contacts, N/C, 16 Amp rated.
31-33	Mains (A-C)-phase voltage sensing input	1.0mm	Connected to (A-C)-phase of mains ( 2A fuse is recommended).
34	Mains N-wire input	1.0mm	Connected to N-wire of mains.
35-37	Genset (A-C)-phase Voltage sensing input	1.0mm	Connect to A-phase of gen-set (2A fuse is recommended).
38	Genset N-wire input	1.0mm	Connected to N-wire of gen-set.
39-41	CT (A-C)-phase sensing input	2.5mm	Outside connected to secondary coil of current transformer(rated 5A).
42	CT COM	2.5mm	Connect to secondary of all monitoring CT's.
43	Temperature 2 Sensor Input	1.0mm	Connect to Temperature Sensor.
44	Oil pressure1 sensor input	1.0mm	Connect to Oil pressure sender.
45	Temperature1 sensor input	1.0mm	Connect to Temperature sender.
46	Fuel level sensor input	1.0mm	Connect to fuel level sensor.
47	Sensor COM	1.0mm	Public terminals of sensor, (B-) have already. connected.
49	RS232GND	0.5mm	Connect to GSM module.
50	RS232TXD		
51	RS232RXD		
52	NC		
53	NC		
	RS232 connector	0.5mm	Connect to the computer. ( 2-RXD、 3-TXD、 5-GND )

**Note : Never run the engine during starting batteries removed, otherwise it will cause the control system due to excessive DC input voltage and burned!**



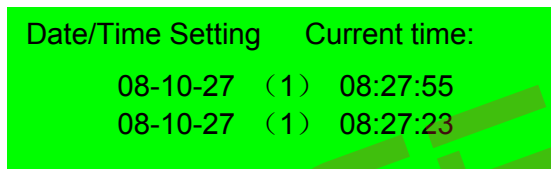

## 7. Parameter setting

### 7.1. Date and time setting:

In the controller start and press  and  In the controller start and press. The interface will display two lines, date and time, the current date and time display, second user behavior modification status display, the black display digital for current user can modify the number, press the + key and key changes to the digital reverse black display, press button can be modified to confirm and tick to the right one. Intermediate parentheses 1 week display, which is composed of microprocessor based on the current set date calculated, the user does not need to be amended.



### 7.2. Operating parameters:

Pressed on the controller start  and , Enter the password to confirm the parameter configuration interface, press the + key or key input corresponding password value 0-9, bit shift by  button, press the ball bond in position fourth, password checking, the password is correct according to the parameters of the main interface of different access password to enter different permissions, password error directly from the. ( factory default password is: 0000) the factory default password users can modify. Press the + key and key parameters can be configured on the screen turning operations, according to tick button on the configuration parameters screen under the present, into the current configuration mode, the current values of the first black display, press the + key or button for the numerical adjustment, shift by  button, the last one to tick button to confirm this setting. The value is stored permanently to the control device of FLASH.

Password Description: The controller has three privilege account;

Default factory settings: 1: Technician password is 0000; 2: Administrator Password: 1234; 3: dynamic password;

The difference between the three users: Only the administrator password and dynamic passwords DTU tie binding or unbinding settlement functions.

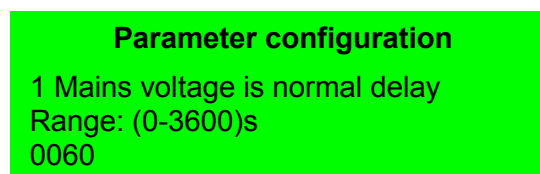

\* **Note:** In the setup process, any time according to  Key can immediately interrupt the current setting of parameters, and returns the operation of standby.

### 7.3. Parameter setting, content and scope of list

No	Menu	Range	Default	Description
1	Mains transient	(0-30s)	10	When the mains voltage from abnormal to normal or abnormal from normal to confirm the time for switching the ATS.
2	Mains Under Voltage	(50-360/624)V	196	When the sampling voltage is below this value, namely that the mains voltage is too low, when set to 30V, low voltage signal is not detected, hysteresis is 10V.
3	Mains Over voltage	(50-360/624)V	264	When the sampling voltage is higher this value, namely that the mains voltage is too high, when set to 620V, high voltage signal is not detected, hysteresis is 10V.
4	Mains Under Frequency	(0-75Hz)	45	
5	Mains Over Frequency	(0-75Hz)	57	
6	Switching Transfer time	(0-100s)	8	From the mains is opened to the gens is close or from the gens is opened to mains close interval times.
7	Start delay	(0-9999s)	1	Time from mains abnormal or remote start signal is active to start genset.
8	Stop Delay	(0-9999s)	1	Time from mains normal or remote start signal is inactive to gen-set stop.
9	Number of starts	(1-10)	3	Fail to start the engine, the maximum number of starts. When you reach the set number of starts, the controller sends start fail signal.
10	Preheat Delay	(0-300s)	0	Time of pre-powering heat plug before starter is powered up.
11	Cranking time	(3-60s)	8	Time of starter power up.
12	Crank Rest Time	(3-60s)	10	The waiting time before second power up when engine start fail.
13	Safety On Delay	(1-60s)	10	Alarms for low oil pressure high temp, under speed, under frequency /voltage, charge fail are inactive.
14	Start Idle Time	(0-3600s)	0	Idle running time of genset when starting.
15	warm-up Time	(0-3600s)	10	Warming time before genset switch on, after it into high speed running.
16	Cooling time	(0-3600s)	10	Radiating time before genset stop, after it unloads.
17	Stop idle time	(0-3600s)	0	Idle running time when genset stop.
18	ETS Solenoid Hold	(0-120s)	20	Stop electromagnet's power on time when genset is stopping.
19	Fail To Stop Delay	(10-120s)	0	When the "ETS output time" is set to 0, the delay from the end of idle time required to complete stop; when "ETS output time" is not equal to 0, the ETS delay from the end to complete stop required of the time.
20	Closing pulse time	(0-5s)	5	Mains closing and gen closing pulse width of 0 means continuous output.

21	Flywheel Teeth	(10-500)TE ETH	118	Tooth number of the engine, for judging of starter separation conditions and inspecting of engine speed. See the installation.
22	Generator abnormal delay	(1-30s)	10	Gens voltage is too high or too low alarm delay.
23	Generator overvoltage (shutdown)	(50-360/ 624)V	265	When the gens voltage is higher than this value and sustained set of "gens abnormal delay" time, which is that the gens voltage is too high, while giving an abnormal shutdown alarm generation. When set to 620V, the voltage is too high the signal is not detected.
24	Generator overvoltage (warning)	(50-360/ 624)V	246	When the gens voltage is higher than this value and sustained set of "gens abnormal delay" time, which is that the gens voltage is too high, while giving gens overvoltage alarm.
25	Generator under voltage (warning)	(50-360/624)V	198	
26	Generator under voltage (shutdown)	(50-360/624) V	176	
27	Under speed (shutdown)	(0-5998RPM)	1200	When the engine speed is lower than this value and lasted 10s, namely that the low speed, under speed alarm stop signal is issued.
28	Under speed (warning)	(1-5999RPM)	1350	
29	Over speed (warning)	(1-5999RPM)	1650	
30	Over speed (shutdown)	(2-6000RPM)	1710	When the engine speed exceeds this value and sustained "speeding delay", namely that over speed alarm stop signal.
31	Over speed shoot	(0-10%)	0	
32	Over speed delay	(0-10s)	2	
33	Generator under frequency (shutdown)	(0-74.8Hz)	40.0	When the generator frequency is below this value and not zero and continuing 10s, namely that low frequency, low frequency alarm stop signal is issued.
34	Generator under frequency (warning)	(1-74.9Hz)	42.0	
35	Generator over frequency (warning)	(1-74.9Hz)	55.0	When the generator frequency exceeds this value and continues 2s, namely that overclocking, overclocking send alarm stop signal.
36	Generator over frequency (shutdown)	(2-75Hz)	57.0	
37	High temperature 1 (warning)	(81-139°C)	90	When the external temperature sensor temperature is greater than this value, send temperature signals. This value will only start after the safety delay judgment, only the temperature sensor input port external temperature sensor judgments. When the value is equal to 140 when the temperature is too high not to issue a signal (only for temperature sensor, programmable input port does not include over temperature alarm signal).
38	High temperature 1 (shutdown)	(82-140°C)	95	
39	High temperature 2 (shutdown)	(81-139°C)	Not used	
40	High temperature 2 (shutdown)	(82-140°C)	Not used	

41	Low oil pressure 1 ( warning )	(1-399)kPa	124	When an external pressure sensor value is less than this value, the delay start oil pressure is too low. This value will only start after the safety delay judgment. When the value is equal to 0, no signal is sent low oil pressure (pressure sensors only, not including programmable input port of the oil pressure alarm signal).
42	Low oil pressure 1 (shutdown )	(0-398)kPa	103	
43	Low oil pressure 2 ( warning )	(1-399)kPa	Not used	
44	Low oil pressure 2 (shutdown)	(0-398)kPa	Not used	
45	Fuel level ( warning )	(0-100)%	10%	
46	Charging failure (warning)	(0-39V)	6	In the generator during normal operation, when the charger D+(WL) voltage is below this value and continues 5s, the issue of charging failure alarm stop.
47	Battery under voltage ( warning )	(0.1-40V)	33	When the battery voltage is higher than this value, and for 20 s, a battery voltage abnormal signals, this value is only warning non-stop.
48	Battery under voltage ( warning )	(0-39.9V)	8	When the battery voltage is lower than this value, and for 20 s, a battery voltage abnormal signals, this value is only warning non-stop.
49	Current transformer	(5-6000:5A)	500	External current transformer ratio. Refers to the generator rated current, over current for load calculations.
50	Over current	(50-120%)	100	When the load current is greater than this percentage, the over current delay.
51	Over current magnification	(1-36)	36	When the load current is greater than the set value and the continued delay time, namely that the overcurrent. (Delay time is calculated).
52	Over current trigger event	(0-2)	2	0: Warning, 1:stop, 2: Trip down
53	Speed loss trigger event	(0-1)	1	0: Warning, 1: stop
54	Output 1 function selection	(0-87)	20	20:Public alarm output
55	Output 1 way	(0-1)	0	0:Normally open output, 1:Normally closed output
56	Output 2 function selection	(0-87)	35	35:ETS output
57	Output 2 way	(0-1)	0	0:Normally open output, 1:Normally closed output
58	Output 3 function selection	(0-87)	0	0:Not User
59	Output 3 way	(0-1)	0	0:Normally open output, 1:Normally closed output
60	Output 4 function selection	(0-87)	78	78:Idle output
61	Output 4 way	(0-1)	0	0:Normally open output, 1:Normally closed output
62	Output 5 function selection	(0-87)	12	12:Gens open
63	Output 5 way	(0-1)	0	0:Normally open output,

				1:Normally closed output
64	Output 6 function selection	(0-87)	14	14:Mains open
65	Output 6 way	(0-1)	1	0:Normally open output, 1:Normally closed output
66	Input function selection 1	(1-29)	13	13:Remote start load
67	Input 1 activation	(0-1)	0	0:Closed Activation, 1:Disconnect Activation
68	Input Trigger Event 1	(0-3)		Controller Fixed setting
69	Valid input 1	(0-3)		
70	Input function selection 2	(1-29)	19	19:High temperature warning input
71	Input 2 activation	(0-1)	0	0:Closed Activation, 1:Disconnect Activation
72	Input Trigger Event 2	(0-3)		Controller Fixed setting
73	Valid input 2	(0-3)		
74	Input function selection 3	(1-29)	20	20:Low oil pressure warning input
75	Input 3 activation	(0-1)	0	0:Closed Activation, 1:Disconnect Activation
76	Input Trigger Event 3	(0-3)		Controller Fixed setting
77	Valid input 3	(0-3)		
78	Input function selection 4	(1-29)	9	9:Mains closed input
79	Input 4 activation	(0-1)	0	0:Closed Activation, 1:Disconnect Activation
80	Input Trigger Event 4	(0-3)		Controller Fixed setting
81	Valid input 4	(0-3)		
82	Input function selection 5	(1-29)	6	6:Gens closed input
83	Input 5 activation	(0-1)	0	0:Closed Activation, 1:Disconnect Activation
84	Input Trigger Event 5	(0-3)		Controller Fixed setting
85	Valid input 5	(0-3)		
86	Input function selection 6	(1-29)	24	24:External alarm input
87	Input 6 activation	(0-1)	0	0:Closed Activation, 1:Disconnect Activation
88	Input Trigger Event 6	(0-3)		Controller Fixed setting
89	Valid input 6	(0-3)		
90	Power-up mode	(0-2)	0	0:Stop Mode, 1:Manual Mode, 2:Automatic mode
91	Module address	(1-254)	1	Controller mailing address.
92	Password Settings	(0-9999)	0000	
93	Starting conditions for success	(0-7)	2	Engine starter separation conditions: generation, magnetic sensors, oil; purpose: to make the starter motor and the engine quickly separated. * Table 7.7
94	Successful start speed	(0-3000RPM)	360	When the engine speed exceeds this value, the unit, starter will disconnect.
95	Successful start frequency	(10-30HZ)	14	When the engine frequency exceeds this value, the unit, starter will disconnect.
96	oil successful start	(0-400kPa)	200	When the engine oil exceeds this value, the unit, starter will disconnect.

97	Successful start D+	(3-32V)	8	Successful start, the D+ terminal voltage.
98	AC System:	(0-3)	0	0: Three-phase four-wire; 1: Two-phase three-wire; 2: Single-phase two-wire; 3: Three-phase three-wire.
99	Gens Poles	(2-16)	4	
100	Temperature1 sensor	(1-13)	4	4:VDO 120 degrees C
101	Temperature2 sensor	(1-13)	1	1: Not used
102	Oil pressure 1 sensor	(1-14)	5	5:VDO 10 bar
103	Oil pressure 2sensor	(1-14)	1	1: Not used
104	Fuel level sensor	(1-11)	1	1: Not used
105	Language	0: Chinese 1:English	0000	
106	Temperature unit selection	0:C 1:F	0000	
107	Pressure unit selection	0-kPa 1-PSI 2-Bar	0000	
108	DTU binding	0:No 1:Yes	0:No	
109	Select Parameters	Range:(1-108)		Parameter setting items quickly jump, user input parameters to be set item number, press OK to jump directly to the related setting items.

**The remaining parameters configuration: only by PC software configuration (table below)**

Parameter name	Factory Defaults
LED1 configuration	The system in automatic mode
LED2 configuration	common to Start Alarm
LED3 configuration	common shutdown alarm
LED4 configuration	common alarm
Genset regular start	No
SMS function is activated	No
Phone number 1-5	No

## 7.4. Programmable output port can be defined content table 1-6

No.	Type	Function Description
1	Not used	
2	Air Flap	Action when over speed shutdown and emergence stop. It also can close the air inflow to stop the engine as soon as possible.
3	Audible Alarm	Action when warning, shutdown, trips. Can be connected annunciator externally. When "alarm mute" configurable input port is active, it can remove the alarm.
4	Battery High Volts	Action when battery's over voltage warning alarm.
5	Battery Low Volts	Action when battery's low voltage warning alarm.
6	reserved	
7	reserved	
8	reserved	
9	Start Relay	Action when genset is starting and disconnect when start is completed.
10	Fuel Relay	Action when genset is starting and disconnect when stop is completed.
11	start time effectively	start time running effective action, no action is invalid.



12	Charge Alt Fail	Action when charge fail warning alarms.
13	Close Generator	Control generator to take load.
14	Generator Pulse close	Pulse generator switch output, the output time from the closing time of the control pulse.
15	Close Mains close	Can be controlled mains switch with overload.
16	Mains Pulse close	Mains switch output pulse, the pulse output time from the closing time control.
17	Combined under & over Frequency warning	The output indicates that either an under frequency or over frequency warning has been activated.
18	Combined under & over Frequency shutdown	The output indicates that either an under frequency or over frequency shutdown has been activated.
19	Combined under & over voltage shutdown	The output indicates that either an under voltage or over voltage shutdown has been activated.
20	Combined under & over voltage warning	The output indicates that either an under voltage or over voltage warning has been activated.
21	Common alarm	The output indicates that a warning, electrical trip or shutdown alarm has been activated. Reset rules as above, depending on whether it is a Warning or a Shutdown fault.
22	Common trip alarm	The output indicates that an electrical trip alarm has been activated. This output can only be reset by removal of the fault and by then pressing the Stop Reset button.
23	Common shutdown alarm	The output indicates that a shutdown alarm has been activated. This output can only be reset by removal of the fault and by then pressing the Stop Reset button or by using an external 'Alarm Reset' Input.
24	Common warning alarm	Action when public warning alarm action.
25	High temperature 1 warning	Action when high temperature 1 warning.
26	High temperature 1 shutdown alarm	Action when high temperature 1 shutdown alarm.
27	Cooling Delay	Action when Cooling Delay.
28	reserved	
29-34	Input port 1-6	Action when Input port 1-6 effective.
35	Emergency Stop	Action when emergency stop alarm.
36	ETS output	Time delay in the ETS within the movement.
37	Fail To Start	Action when Starting failure alarm.
38	Fuel pump control	The fuel level upper and lower limit to control its motion.
39	Gen effective	The generator cooling during normal operation and high-speed action.
40	Gen Over Frequency Warn	Action when generator over frequency warning.
41	Gen over frequency shutdown alarm	Action when generator over frequency shutdown alarm.
42	Gen over voltage warn	Action when generator overvoltage warning.
43	Gen overvoltage shutdown	Action when generator overvoltage shutdown.
44	Gen under frequency warning	Action when generator under frequency warning.
45	Gen under frequent shutdown	Action when generator under frequency shutdown.
46	Gen undervoltage warning	Action when generator undervoltage warning.

47	Gen undervoltage shutdown	Action when generator undervoltage shutdown.
48	Louver Control	Action in genset starting and disconnect when genset stopped completely.
49	Low fuel level	Action when Low fuel level.
50	Speed signal loss	In safe operation, the engine speed detection equal to 0 action.
51	Mains abnormal	Mains over and under frequency, overvoltage, undervoltage, auxiliary mains abnormal input effective action.
52	Mains Over Frequency	Action when mains over frequency.
53	Mains overvoltage	Action when mains overvoltage.
55	Mains underfrequency	Action when mains underfrequency.
56	Mains undervoltage	Action when mains undervoltage.
57	Low oil pressure 1 warn	Action when low oil pressure1 warning.
58	Low oil pressure 1 shuidown	Action when low oil pressure 1 shutdown.
59	Oil pressure sensor open	Action when oil pressure sensor open.
60	Open Generator	Control generator to take load.
61	Gens Pulse Open	Generator pulse switch output, output time divided by the gate pulse time control.
62	Open Mains	Control generator to take load.
63	Mains Pulse Open	Mains pulse switch output, output time divided by the gate pulse time control.
64	Overcurrent warning	Action when generators over-current warning.
65	Overcurrent trip	Action when generators over-current tripping.
66	Overspeed warning	Action when engine overspeed warning action.
67	Overspeed warning	Action when engine overspeed shutdown alarm action.
68	Pre-heat (during preheat timer)	The output controls the pre-heater. Pre-heat output is available for the duration of the pre-heat timer, which terminates prior to cranking.
69	Pre-heat (until end of cranking)	The output controls the pre-heater. As 'Pre -heat (during preheat timer)' mode but pre-heat is also available during cranking.
70	Pre-heat (until end of warming)	The output controls the pre-heater. As 'Pre-heat (until safety on)' but pre-heat is also available while waiting for the delayed alarms to become active.
71	Pre-heat (until safety on)	The output controls the pre-heater. As 'Pre -heat (until end of cranking)' but pre-heat is also available while waiting for the delayed alarms to become active.
72	Open breaker	This output source is intended to be used to control the load switching device. Whenever the 6320 module has taken load t his control source will be active.
73	In manual mode	System in the manual test machine mode of action.
74	System in Auto Mode	The output indicates that the module is in the Auto mode.
75	System in Manual Mod	This output indicates that the module is in the manual mode.
76	System in Stop Mode	The output indicates that the module is in the Stop mode.
77	Under speed warning	This output indicates that an under speed warning (pre -alarm) has occurred.
78	Under speed Shutdown	This output indicates that an under speed shutdown has occurred.
79	Automatic stop prohibited	In the automatic mode, the generator during normal operation, when the automatic shutdown disable input effective action.

80	Idle/ run control	This output is active from cranking, continues to be active until the start idle timer has elapsed; Also this output is active during the period of the stop idle timer, continues to be active until the engine has stopped.
81	The oil output	In the starting - Safety during operation action.
82	Raise speed	This output is active during the warming up timer.
83	Excite generator	This output is available for the period of the crank timer. This output will energize for 2 second during the period of the safety on timer if generator has no voltage.
84	Drop speed	This output is available during the period of the coolant down timer, and remain until the engine has stopped.
85	Oil pressure output	Action during the safe operation of preheating.
86	High temperature 2 warning	Action when high temperature 2 warning alarm.
87	High temperature 2 shutdown	Action when high temperature 2 shutdown alarm.
88	Low oil pressure 2 warning	Action when low oil pressure2 warning.
89	Low oil pressure 2 shutdown	Action when low oil pressure2. shutdown.

## 7.5. Programmable input port 1-6 definition content list

No.	Type	Function Description
1	Alarm Mute	Can prohibit "Audible Alarm" output when input is active.
2	Inhibit Alarm Stop	All shutdown alarms are prohibited except emergence stop.(Means battle mode or override mode)
3	Inhibit Auto Stop	In Auto mode, during generator normal running, when input is active, inhibit generator shutdown automatically. (This function is only LXC6320/5120)
4	Inhibit Auto Start	In Auto mode, inhibit generator start automatically when input is active..
5	Aux Mains Fail	In Auto mode, mains are abnormal when input is active.
6	Aux Gens Closed	Connect generator loading switch's Aux. Point.
7	Inhibit Gens Load	If the generator has been loaded, the input is not its function, when the generator is not loaded, when the input is valid, the load does not allow the generation after normal operation.
8	Lamp Test	All LED indicators are illuminating when input is active.
9	Aux Mains Closed	Connect mains loading switch is Aux. Point.
10	Inhibit Mains Load	When the input is valid, Forbidden City electric load, has been loaded immediately uninstall.
11	Panel key ban	When the input is valid, the panel all keys do not its role, the panel LCD The first screen the first line on the right shows.
12	Remote Start( Not on Load)	In the automatic mode, when the input is valid, and can automatically open the turbine, generator normal operation is not loaded. When the input is invalid, can automatically stop generating set.
13	Remote Start(on Load)	In the automatic mode, when the input is valid, and can automatically open the turbine, generator normal operation after loading. When the input is invalid, can automatically stop generating set.
14	Inhibit Scheduled	In Auto mode,inhibit scheduled run genset when input is active.
15	Aux Mains OK	In Auto mode,mains are normal when input is active.

16	User Configured	
17	High Temperature	Connected temperature sensor switch input.
18	Low Oil Pressure	Then oil pressure sensor switch input.
19	High Temperature Warning	Connected temperature sensor switch input.
20	Low Oil Pressure Warning	Then oil pressure sensor switch input.
21	Inhibit SMS Start	Inhibit by SMS control start.
22	Low Fuel Level Warning	Then fuel level sensor switch input.
23	Overspeed Shutdown	When active, the controller performs an overspeed shutdown action.
24	External Alarm	When activated, the panel will display an alarm.
25	Over Current Trip	When active, the panel displays an overcurrent alarm input.
26	Damper Switch Feedback	When the damper is closed, the switching action. Used to confirm whether the damper is closed.
27	Instrument Mode	When active, the panel display system in the monitor mode, only the electric generator set monitoring parameters and alarm signal.
28	Raise Speed	Corresponding output raise speed control.
29	Drop Speed	Corresponding output drop speed control.

## 7.6. Custom Project Name List

序号	类型	说明
1	High Water Temperature Input	When active, the panel displays the high water temperature input alarm.
2	Low Oil Pressure Input	When active, the panel displays the low oil pressure input alarm.
3	High Oil Temperature Input	When active, the panel displays the high oil temperature input alarm.
4	Box High Temperature Input	When active, the panel displays the box high temperature input alarm.
5	Low Level Input	When active, the panel displays the low level input alarm.
6	Low Oil Level Input	When active, the panel displays the low oil level input alarm.
7	Over Speed Input	When active, the panel displays the over speed input alarm.
8	External Alarm Input	When active, the panel displays the external input alarm.
9	Over Current Input	When active, the panel displays the over current input alarm.
10	Half Oil Level Input	When active, the panel displays half the oil level level input alarm.
11	Monitor Mode Input	When active, the panel display system in the monitor mode, only the genset electric monitoring parameters and alarm signal (low speed, low voltage alarm is not monitored)
<b>Note: The input port 1-6, only use computer software to configure.</b>		

## 7.7. Sensor selection list

No.	entry	Content	Remarks
1	temperature sensor	1 Do not use 2 digital input low effective 3 digital input high effective 4 VDO 120 degrees C 5 Datcon high 6 Datcon low 7 SGX 120 degrees C 8 Cummins 9 SGH 120 degrees C 10 Curtis 11 SGD 120 degrees C 12 Pt100 13 User defined	Custom resistive input resistance range of 0-999 Europe, silently think factory VDO 120 degrees C curve. User defined temperature curve through the PC software settings.
2	pressure sensor	1 Do not use 2 digital input low effective 3 digital input high effective 4 VDO 5 bar 5 VDO 10 bar 6 Datcon 5 bar 7 Datcon 10 bar 8 Datcon 7 bar 9 SGX 10 bar 10 CMB812 11 SGH 10 bar 12 Curtis 13 SGD 10 bar 14 User defined	Custom resistive input resistance range of 0-999 Europe, the factory silence that VDO 10 bar curve. User defined pressure curve through the PC software settings.
3	fuel level sensor	1 not used 2 Digital input low effective 3 High efficient digital input 4 VDO Ohm range (10-180) 5 VDO Tube type (90-0) 6 US Ohm range (240-33) 7 GM Ohm range (0-90) 8 GM Ohm range Ohm range (0-30) 9 Ford (73-10) 10 NKZR12/24-1-04 Ohm range (100-0) 11 User defined	Custom resistive input resistance range of 0-999 Europe, the factory silence that VDO 10 bar curve. User defined pressure curve through the PC software settings.

## 7.8. Successful starting condition selection list

No.	Set the content
0:	Speed sensor
1:	Oil Pressure
2:	Speed sensor + Gens frequency
3:	Speed sensor + Oil Pressure
4:	Gens frequency + Oil Pressure
5:	Gens frequency + Speed sensor + Oil Pressure
6:	Charger D+
7:	Oil Pressure + Charger D+

**Successful start condition setup considerations:**

- 1: Starter and the engine, there are four separate conditions, the magnetic sensor, gens frequency, oil pressure, charge D, both may be used alone. Recommended oil pressure must comply with magnetic sensors, gens simultaneously, purpose is to make the starting motor and engine as soon as possible separation and accurate judgment starting successfully.
- 2: Magnetic sensor is a magnetic device is installed in the engine block detection flywheel tooth number.
- 3: When choosing the magnetolectric sensor, ensures that the engine flywheel tooth number and the set value, otherwise it may appear overspeed shutdown or less speed down.
- 4: If the generator without magnetolectric sensor, please do not select the corresponding item, or there will be a starting unsuccessful or speed loss of signal alarm shutdown.
- 5: If the generating units without oil pressure sensor, please do not select the corresponding item.
- 6: If successful starting conditions did not choose the generator, related to power the controller does not capture and display power ( which can be applied to the pump unit ), if the start condition did not choose the magnetic sensor, the controller display speed by power signal conversion.
- 7: If the generator without magnetolectric sensor and Oil pressure sensor, the “ Charger D+” is optional as a starter motor separation conditions. It is recommended to select “Oil Pressure + Charger D+” for safety.

## 8. COMMISSIONING

Please make the under procedures checking before commissioning,

1. Ensure all the connections are correct and wires diameter is suitable.
2. Ensure that the controller DC power has fuse, controller's positive and negative connected to start battery are correct.
3. Emergence stop must be connected with positive of start battery via scram button's normal close point and fuse.
4. Take proper action to prevent engine to crank disconnect (e. g. Remove the connection wire of fuel value). If checking is OK, make the start battery power on; choose manual mode and controller will executive routine.
5. Set controller under manual mode, press “start” button, genset will start. After the setting times as setting, controller will send signal of Start Fail; then press “stop” to make controller as reset.
6. Recover the action of stop engine start (e. g. Connect wire of fuel value), press start button again, genset will start. If everything goes well, genset will normal run after idle running (if idle run be set). During this time, please watch for engine's running situations and AC generator's voltage and frequency. If abnormal, stop genset running and check all wires connection according to this manual.
7. Select the AUTO mode from controller's panel, connect mains signal. After the mains normal delay, controller will transfer ATS (if fitted) and into mains load. After cooling time, controller will stop genset and make it in to “at rest” mode until there is abnormal of mains.
8. When mains is abnormal again, genset will be started automatically and into normal running, then controller send signal to make generator switch on, and control the ATS as generator load. If not like this, please check ATS' wires connection of control part according to this manual.
9. If there is any other question, please contact Feirui's service.

## 9. Typical applications

1、GPRS MODEM recommended Dongguan Feirui Electronics Co., Ltd. is equipped with LXI680( need to buy separately ), RS232 Communication lines connected correctly according to the figure.

2、If the engine starting voltage for 24V battery, measure the starter output, fuel outlet and downtime starting output outlet (depending on user configuration) of battery cathode resistance should not be less than 2 ohms, if less than 2 ohm please also extended the corresponding output current greater than 30 a relay. If engine starting battery voltage is 12V, measurement start output, fuel outlet and downtime starting output outlet for battery cathode resistance should not be less than 1 ohm, if less than 1 ohm please also extended the corresponding output current greater than 30 a relay.

### Three-phase three wire connection wiring diagram (in the case of the LXC6320/5120)

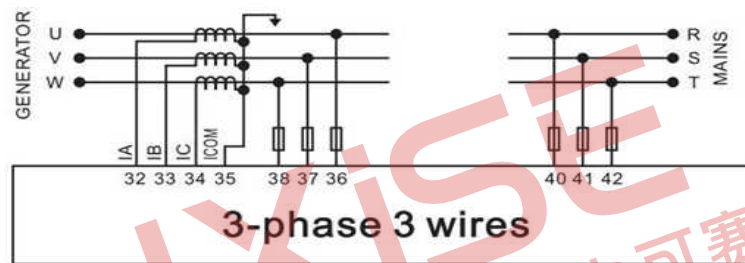

### The single-phase two-wire connection wiring diagram ( in the case of the LXC6320/5120)

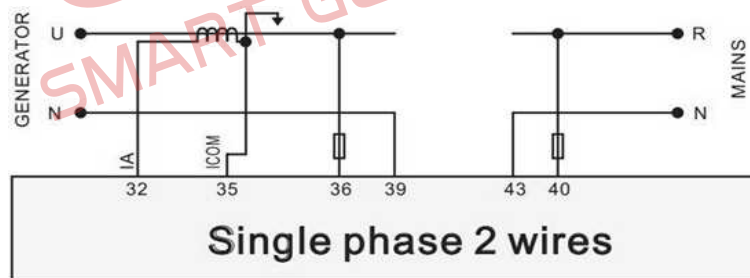

### Two-Phase three wire connection wiring diagram ( in the case of the LXC6320/5120)

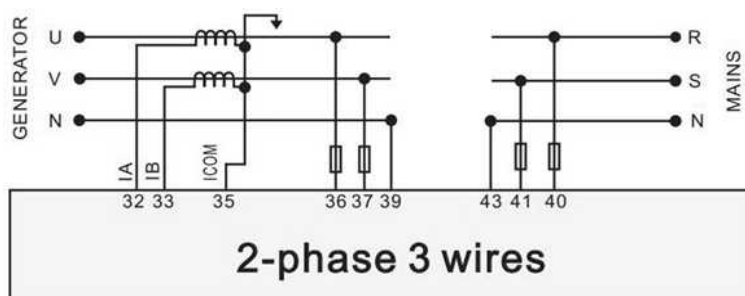

### LXC6310/5110 Typical application diagram

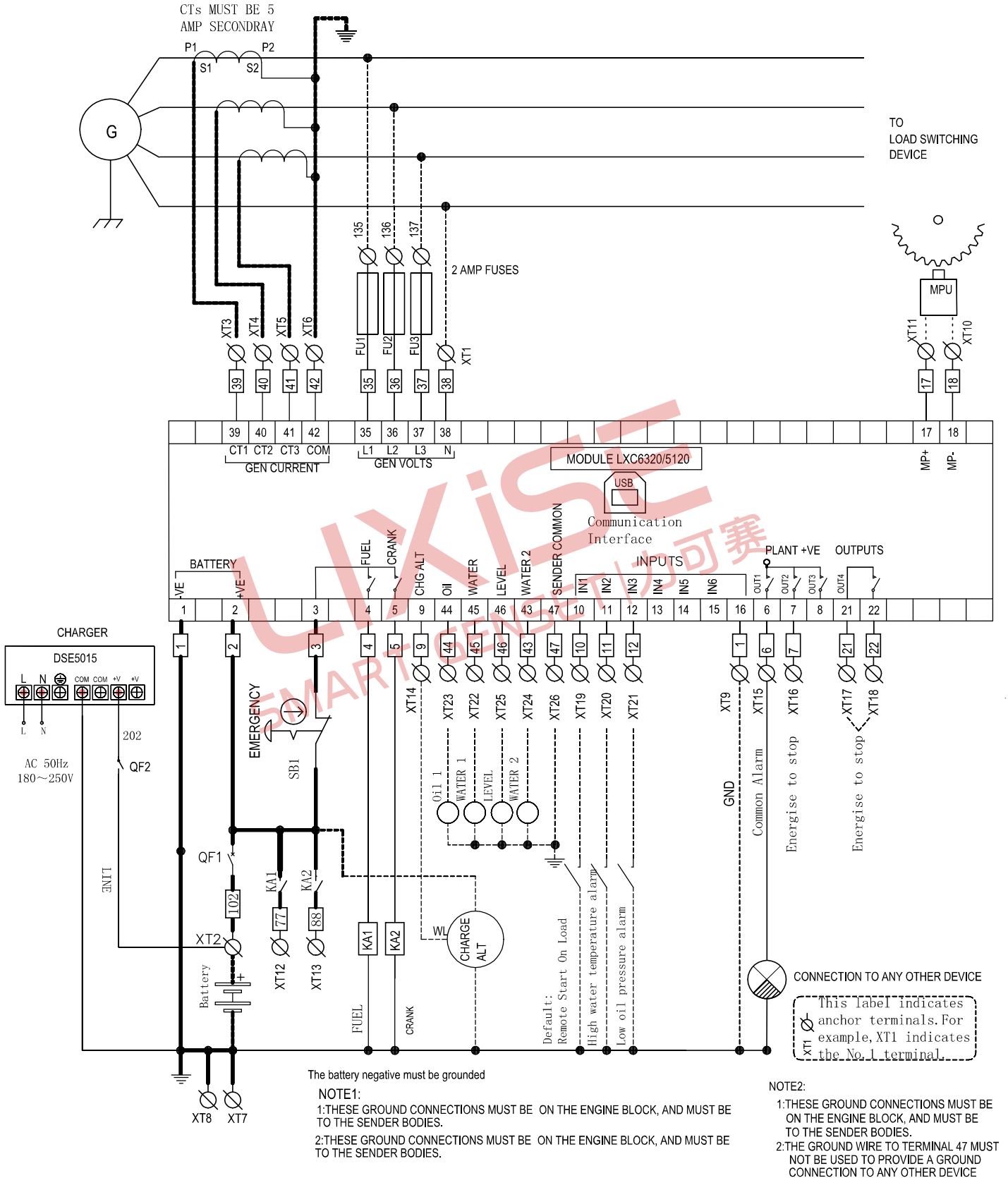



### LXC6320/5120 Typical application diagram

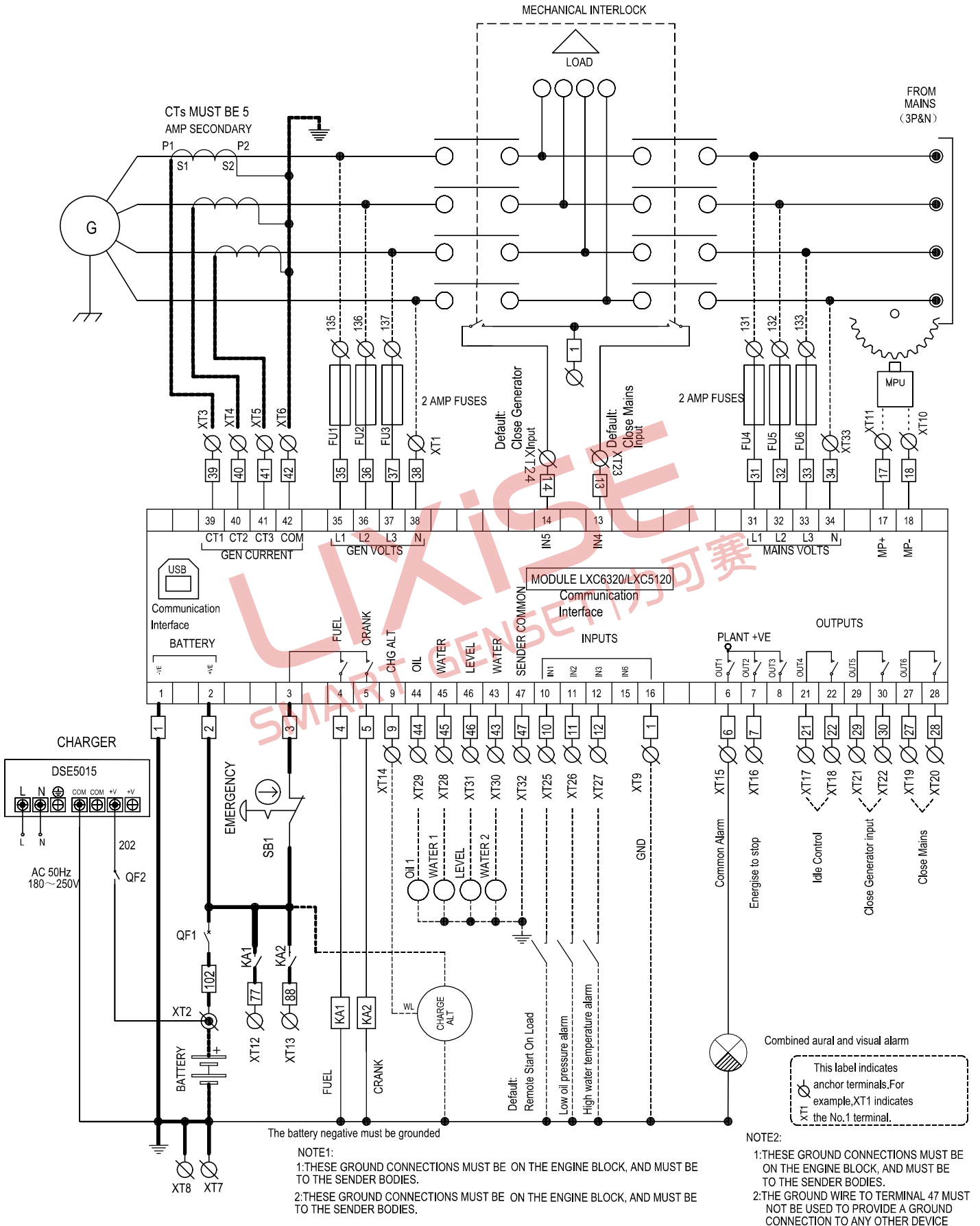

## Installation

LXC63X0/LXC51X0 Controller is panel built-in design; it is fixed by clips when installed.

The controller's overall dimensions and cutout dimensions for panel, please refer to as following:

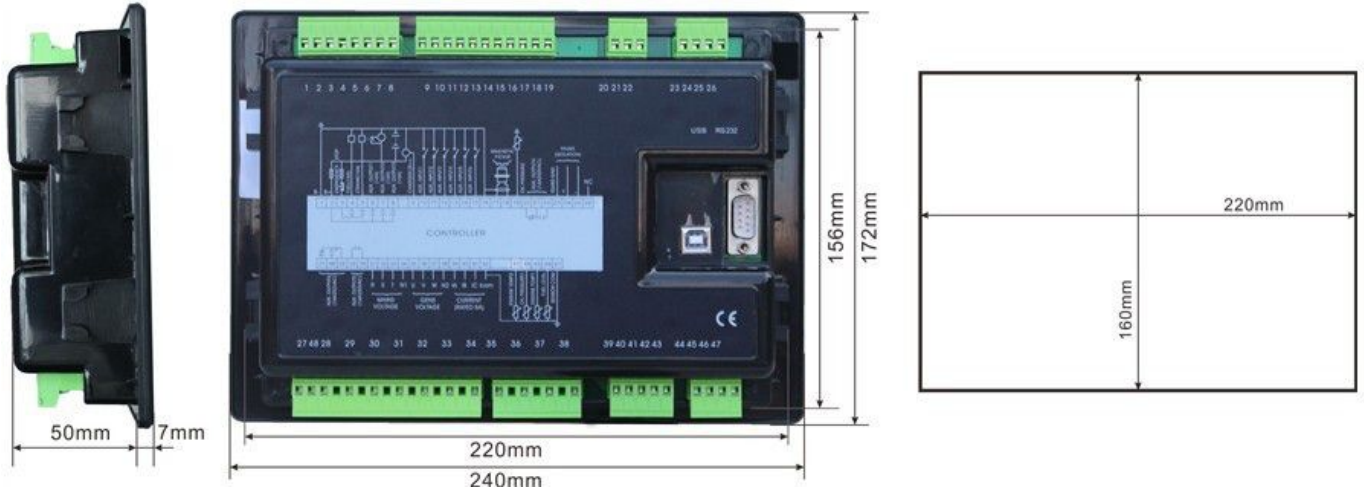

### 1. Battery Voltage Input

LXC63X0/LXC51X0 series controller can suit for widely range of battery voltage (8~35) VDC. Negative of battery must be connected with the shell of starter stable. The diameter of wire which from power supply to battery must be over 2.5mm<sup>2</sup>. If floating charge configured, please firstly connect output wires of charger to battery's positive and negative directly, then, connect wires from battery's positive and negative to controller's positive and negative input ports in order to prevent charge disturbing the controller's normal working.

### 2. Speed Sensor Input

Speed sensor is the magnetic equipment which be installed in starter and for detecting flywheel teeth. Its connection wires to controller should apply for 2 cores shielding line. The shielding layer should connect with No. 16 terminal in controller while another side is hanging in air. The else two signal wires are connected with No.17 and No.18 terminals in controller. The output voltage of speed sensor should be within (1~24) VAC (effective value) during the full speed. AC12V is recommended (in rated speed). When install the speed sensor, let the sensor is spun to contacting flywheel first, then, port out 1/3 lap, and lock the nuts of sensor at last.

### 3. Output And Expand Relays

All outputs of controller are relay contact output type. If need to expand the relays, please add freewheel diode to both ends of expand relay's coils (when coils of relay has DC current) or, increase resistance-capacitance return circuit (when coils of relay has AC current), in order to prevent disturbance to controller or others equipment.

### 4. AC Input

LXC63X0/LXC51X0 Current input of controller must be connected to outside current transformer. And the current transformer's secondary side current must be 5A. At the same time, the phases of current transformer and input voltage must correct. Otherwise, the current of collecting and active power maybe not correct. *Note: a. ICOM port must be connected to negative pole of battery controller power. b. When there is load current, transformer's secondary side prohibit from open circuit.*

## 5. Withstand Voltage Test

When controller had been installed in control panel, if need the high voltage test, please disconnect controller's all terminal connections, in order to prevent high voltage into controller and damage it.

## 10. Common Faults And Exclusion Method

Following in my company controller process more common failure and exclusion method, if there is a failure of the other can not be solved, please contact my company.

Faults	Possible Solutions
Controller no response with power.	Check starting batteries; Check controller connection wirings; Check DC fuse.
Genset shutdown	Check the water/cylinder temperature is too high or not; Check the genset AC voltage; Check DC fuse.
Controller emergency stop	Check emergence stop button is correct or not; Check whether the starting battery positive be connected with the emergency stop input; Check whether the circuit is open.
Low oil pressure alarm after crank disconnect	Check the oil pressure sensor and its connections.
High water temp alarm after crank disconnect	Check the temperature sensor and its connections.
Shutdown Alarm in running	Check related switch and its connections according to the information on LCD; Check programmable inputs.
Crank not disconnect	Check fuel oil circuit and its connections; Check starting batteries; Check speed sensor and its connections; Refer to engine manual.
Starter no response	Check starter connections; Check starting batteries.
Genset running while ATS not transfer	Check ATS; Check the connections between ATS and controllers.

## 11. Product Packaging

The final package of this product should contains:

- (1) 1 piece of controller model.
- (2) 4 pieces of fixed cards.
- (3) 1 piece of product certificate.
- (4) 1 piece of product manual

Dongguan Feirui Electronics Co.,LTD.

Tel:86-0769-23162896

Fax:86-0769-23166296

<http://www.lixise.com>

<http://www.dgfeirui.en.alibaba.com>

E-mail:sales@smartgenset.com

Add: 18# Chashang industrial zone,  
WenTang Road Dongguan City,  
Guangdong, China